

CROWN

C-B

2,500 - 3,500 kg Capacity

Specifications

Electric Counterbalance Lift Truck
80 V



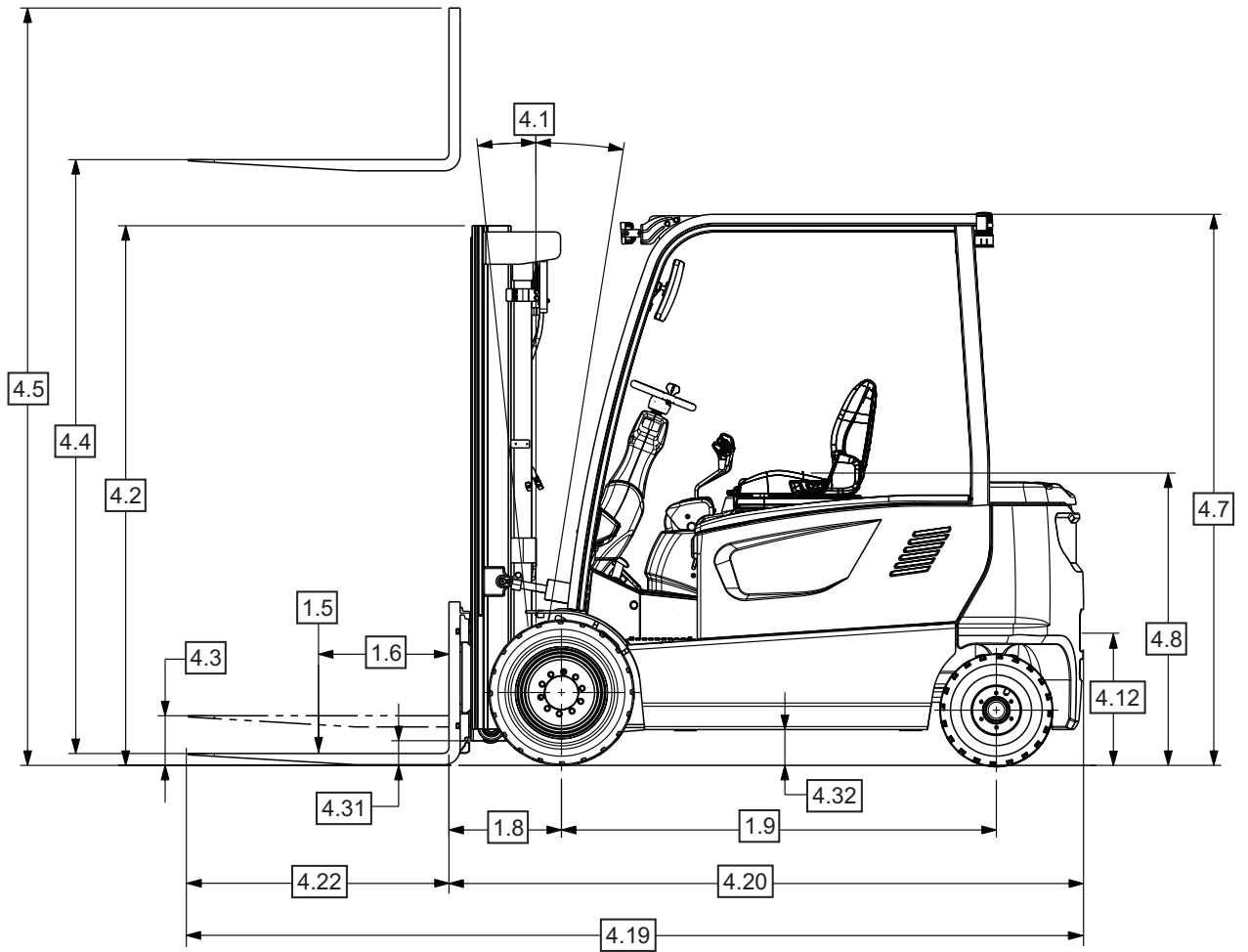
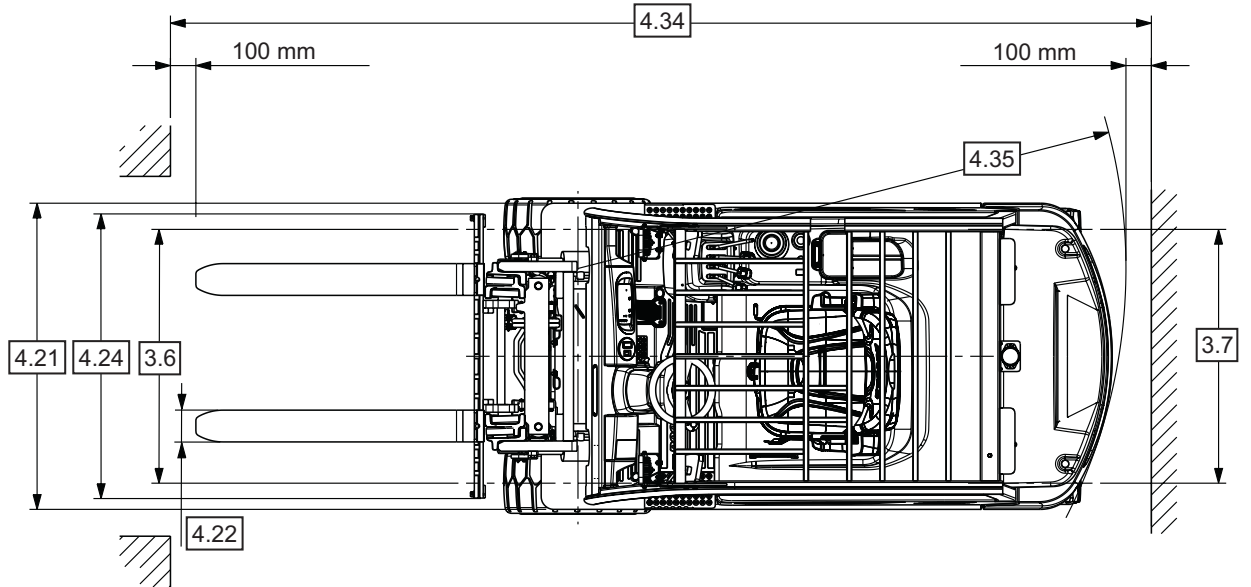

C-B 25-35 Series

**Electric Counterbalance
Lift Truck 80 V**

					C-B 25 X-7			C-B 30 X-7			C-B 35 X-7		
Distinguishing Mark	1.2	Model											
	1.3	Power Source	Electric, Diesel, LPG, Gasoline					Electric					
	1.4	Operator Type					Sit-down Rider Counterbalance						
	1.5	Rated Capacity		Q	t	2.5	3.0	3.5					
	1.6	Load Centre	Fork face to Llad CG	c	mm	500							
	1.8	Load Distance	Center of wheel to fork face	x	mm	448	454						
	1.9	Wheelbase		y	mm	1589	1734	1750					
Weight	2.1	Service Weight	Less battery		kg	4623	5068	5486					
	2.2	Axle Load	With load front / rear		kg	6275/848	7197/870	7940/1046					
	2.3	Axle Load	Without load front / rear		kg	2284/2339	2547/2521	2532/2954					
Tyres/Wheels/Chassis	3.1	Tyres				Pneumatic / Super Elastic							
	3.2	Tyre Size	Front, OD x Width x Rim Dia.		mm	23 x 10-12							
	3.3	Tyre Size	Rear, OD x Width x Rim Dia.		mm	18 x 7-8							
	3.5	Wheels	Number (x=driven) front/rear			2x / 2							
	3.6	Tread	Front	b ₁₀	mm	998							
	3.7	Tread	Rear	b ₁₁	mm	998							
	Dimensions	4.1	Mast Tilt, Fork Carriage	Forward / backward	α / β	°	6 / 9						
4.2		Mast Collapsed Height		h ₁	mm	2160							
4.3		Free-lift		h ₂	mm	147	152	152					
4.4		Lift Height		h ₃	mm	3230			3000				
4.5		Mast Extended Height		h ₄	mm	3990			3760				
4.7		Overhead Guard Height		h ₆	mm	2185	2210						
4.8		Seat Height	Relating to SIP/stand height	h ₇	mm	1070							
4.12		Coupler Height		h ₁₀	mm	392							
4.19		Overall Length		l ₁	mm	3379	3530	3614					
4.20		Head Length	Length to fork face	l ₂	mm	2329	2480	2564					
4.21		Overall Width		b ₁	mm	1245							
4.22		Fork Dimension	DIN ISO 2331	s/e/l	mm	40 x 100 x 1050	45 x 125 x 1050						
4.23		Fork Carriage	ISO 2328, Class/Type A, B		class	II	III	III					
4.24		Fork Carriage Width		b ₃	mm	1103	1115						
4.31		Ground Clearance	With load, below mast	m ₁	mm	130							
4.32			With load, centre wheelbase	m ₂	mm	140							
4.34.1		Aisle Width	For pallets 1000x1200 crossways	A _{st}	mm	3620	3772	3832					
4.34.2			For pallets 800x1200 lengthways	A _{st}	mm	3799	3950	4010					
4.35		Turning Radius		W _a	mm	1950	2095	2155					
4.36	Internal Turning Radius		b ₁₃	mm	348	340							
Performance Data	5.1	Travel Speed	With load / without load		km/h	16 / 18							
	5.2	Lift Speed	With load / without load		m/s	0.48/0.60	0.42/0.60	0.38/0.60					
	5.3	Lowering Speed	With load / without load		m/s	0.49 / 0.46			0.50 / 0.46				
	5.6	Max. Drawbar Pull	With load / without load (5 min. rating)		N	17338 / 16426							
	5.8	Max. Gradeability	With load / without load (5 min. rating)		%	25/38	22/34	20/31					
	5.9	Acceleration Time	With load / without load		s	4.85 / 4.75							
	5.10	Service Brake	Service brake			Foot / Hydraulic							
	Parking brake					Electric							
Electric Motor	6.1	Traction Motor	60 min. rating		kW	10 x 2							
	6.2	Pump Motor	Lift motor rating at S3 15%		kW	21							
	6.3.1	Battery	According to DIN 43531/35/36 A, B, C, no			DIN43536A							
	6.3.2		Compartment dimensions	lxwxh	mm	1040 x 720 x 805	1040 x 865 x 805						
	6.4	Battery Voltage	Nominal capacity 5h		V / Ah	80 / 620	80 / 775						
	6.5	Battery Weight	Min		kg	1560	1870						
6.6	Energy Consumption according to DIN EN 16796					kW/h	8.1						
10.2	Oil Volume for Attachments				bar/lpm	155/26							
10.7	Sound Pressure Level at the Operator's Seat					dB(A)	68						

Note: Values listed in the specification sheet have been rounded. Performance may vary due to operation conditions and / or forklift configurations. Products and specifications are subject to change without prior notice.

Mast Chart C-B 25 X-7

Mast Type	Maximum Fork Height h_3	Mast Collapsed Height h_1	Mast Extended Height h_4		Mast Free-lift Height h_2		Rated Load Capacities					
			With Load Backrest	Without Load Backrest	With Load Backrest	Without Load Backrest	Tilt Angle				Load Capacities	
							Single Pneumatic		Single Super Elastic		Single Pneumatic	Single Super Elastic
			FWD	BWD	FWD	BWD	LC 500 mm	LC 500 mm				
	mm	mm	mm	mm	mm	mm	deg	deg	deg	deg	kg	kg
TL	2950	2020	4200	3735	147	147	6	9	6	9	2500	2500
	3230	2160	4480	4015	147	147	6	9	6	9	2500	2500
	3500	2410	4755	4290	147	147	6	9	6	9	2500	2500
	3800	2560	5055	4590	147	147	6	9	6	9	2500	2500
	3950	2635	5205	4740	147	147	6	9	6	9	2500	2500
	4350	2835	5605	5140	147	147	6	9	6	9	2500	2500
	4960	3135	6205	5740	147	147	6	9	6	9	2425	2450
TF	2950	2020	4200	3665	815	1350	6	9	6	9	2500	2500
	3230	2160	4480	3945	955	1490	6	9	6	9	2500	2500
	3600	2410	4855	4320	1205	1740	6	9	6	9	2500	2500
TT	3900	1885	5155	4620	680	1215	6	9	6	9	2500	2500
	4290	2020	5560	5025	815	1350	6	9	6	9	2500	2500
	4730	2160	5980	5445	955	1490	6	9	6	9	2475	2500
	4805	2165	6055	5520	980	1515	6	9	6	9	2450	2475
	5560	2510	6805	6270	1305	1840	6	5	6	9	2275	2325
	6010	2660	7255	6720	1455	1990	6	5	6	9	1700	2250

Mast Chart C-B 30 X-7

Mast Type	Maximum Fork Height h_3	Mast Collapsed Height h_1	Mast Extended Height h_4		Mast Free-lift Height h_2		Rated Load Capacities					
			With Load Backrest	Without Load Backrest	With Load Backrest	Without Load Backrest	Tilt Angle				Load Capacities	
							Single Pneumatic		Single Super Elastic		Single Pneumatic	Single Super Elastic
			FWD	BWD	FWD	BWD	LC 500 mm	LC 500 mm				
	mm	mm	mm	mm	mm	mm	deg	deg	deg	deg	kg	kg
TL	2950	2020	4200	3795	152	152	6	9	6	9	3000	3000
	3230	2160	4480	4075	152	152	6	9	6	9	3000	3000
	3500	2410	4755	4350	152	152	6	9	6	9	3000	3000
	3800	2560	5055	4650	152	152	6	9	6	9	3000	3000
	3950	2635	5205	4800	152	152	6	9	6	9	3000	3000
	4350	2835	5605	5200	152	152	6	9	6	9	2950	2975
	4960	3135	6205	5800	152	152	6	5	6	5	2800	2825
TF	2950	2020	4200	3720	820	1300	6	9	6	9	3000	3000
	3230	2160	4480	4000	960	1440	6	9	6	9	3000	3000
	3600	2410	4855	4375	1210	1690	6	9	6	9	3000	3000
TT	3900	1885	5155	4675	685	1165	6	9	6	9	2900	2900
	4290	2020	5560	5080	820	1300	6	9	6	9	2900	2900
	4730	2160	5980	5500	960	1440	6	9	6	9	2850	2875
	4805	2185	6055	5575	985	1475	6	9	6	9	2850	2875
	5560	2510	6805	6325	1310	1790	6	9	6	9	2300	2700
	6010	2660	7255	6775	1460	1940	6	9	6	9	1775	2600

Note: Mast specifications and rated capacities are based on standard truck configuration.

Mast Chart C-B 35 X-7

Mast Type	Maximum Fork Height h_3	Mast Collapsed Height h_1	Mast Extended Height h_4		Mast Free-lift Height h_2		Rated Load Capacities					
			With Load Back-rest	Without Load Back-rest	With Load Back-rest	Without Load Back-rest	Tilt Angle				Load Capacities	
							Single Pneumatic		Single Super Elastic		Single Pneumatic	Single Super Elastic
			FWD	BWD	FWD	BWD	LC 500 mm	LC 500 mm				
	mm	mm	mm	mm	mm	mm	deg	deg	deg	deg	kg	kg
TL	2720	2020	3970	3695	152	152	6	9	6	9	3500	3500
	3000	2160	4250	3975	152	152	6	9	6	9	3500	3500
	3495	2410	4750	4475	152	152	6	9	6	9	3500	3500
	3655	2560	4905	4630	152	152	6	9	6	9	3500	3500
	3805	2635	5055	4780	152	152	6	9	6	9	3500	3500
	4805	3135	6055	5780	152	152	6	5	6	9	3125	3425
TF	2720	2020	3970	3670	820	1120	6	5	6	9	3500	3500
	3000	2160	4250	3950	960	1260	6	5	6	9	3500	3500
	3495	2410	4745	4445	1210	1510	6	5	6	9	3500	3500
TT	3555	1885	4805	4505	685	985	6	9	6	9	3400	3400
	3960	2020	5210	4910	820	1120	6	9	6	9	3400	3400
	4380	2160	5630	5330	960	1260	6	9	6	9	3300	3400
	4820	2330	6070	5770	985	1430	6	5	6	9	3175	3400
	5205	2510	6455	6155	1310	1610	6	5	6	9	2575	3300
	5655	2660	6905	6605	1460	1760	6	5	6	5	2000	3200

Note: Mast specifications and rated capacities are based on standard truck configuration.

Standard Features

1. 80 V electrical system
2. AC motor and hydraulic systems
3. Regenerative braking
4. Electronically assisted braking
5. Emergency switch
6. Manual lever controls
7. Directional control on lift lever
8. Power steering
9. Intuitive instrument panel
 - LCD screen
 - Brake oil level indicator
 - selectable operation mode (E/S/H)
 - Turtle mode
 - Steering angle
10. Unlimited ramp hold
11. Speed reduction in turns
12. Weight indicator (hydraulic pressure sensing)
13. Low battery alarm
14. Operator Presence Sensor
15. Sound suppression
16. Operator design features
 - Entry handle
 - Wide spacious floorboard
 - Adjustable steer column
 - Suspension seat, vinyl
 - Clear-view overhead guard and mast design
 - USB port in armrest
 - 12 V electrical outlet
 - Cup holder
17. Rugged steer axle with large king pins and tapered roller bearings
18. Pneumatic tyres
19. DIN battery connector
20. IP65 rated controllers
21. IP43 rated motors

Optional Equipment

1. TL,TF and TT Mast
2. Additional operator design features
 - Fingertip controls with integrated directional control switch
 - Foot-operated directional control panel
 - Premium suspension seat, vinyl or fabric
 - Rear handle
 - Various mirrors
 - Smart zone speed control
 - Tilt Position Assist
3. Lights
 - LED Front worklights with turn signals
 - LED Rear worklights
4. Audible warning devices
 - Back-up Alarm
5. Visual warning devices
 - Flashing light
 - Floor spot light (blue light)
 - Floor linelight
6. Hard Cab
 - incl. heater
7. Rear handle
8. Cooling fan
9. Attachments
 - Hang-on sideshifter
 - Fork positioner with integrated sideshifter
10. Super elastic tyres
11. Non-marking super elastic tyres
12. Load backrest
13. Freezer conditioning
14. Battery rollers
15. Belly pan
16. SBE battery connector
17. Tilt cylinder bellows
18. Quick disconnect hydraulics
19. Enclosed hydraulic and drive pump motors
20. Tool kit
21. InfoLink® Ready

Warning Device Notes

Audible or visual alerts

Safety considerations and dangers associated with audible travel alarms and lights include:

- Multiple alarms and/or lights can cause confusion.
- Workers ignore the alarms and/or lights after day-in and day-out exposure.
- Operator may transfer the responsibility for “looking out” to the pedestrians.
- Annoys operators and pedestrians.

Other Options Available

Contact Crown for additional options.

Dimensions and performance data given may vary due to manufacturing tolerances. Performance is based on an average size vehicle and is affected by weight, truck condition, truck equipment and the conditions of the operating area. Crown products and specifications are subject to change without notice.